

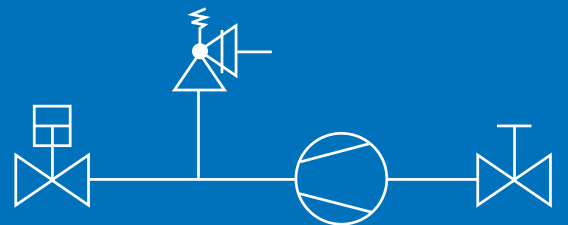

Dry-running piston compressors

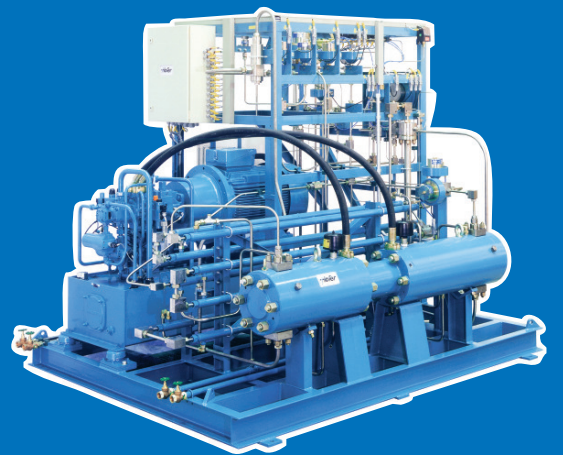

high tech in high pressure

Diaphragm
Compressors

Piston
Compressors

Pressurizing
Systems

Valves
Fittings

Hofer-
Service

certified to
ISO 9001
by TÜV CERT

certified to
PED Module H
by TÜV CERT

HOFER piston compressors with hydraulic drive unit



Dry-running HOFER piston compressors with hydraulic drive unit, type TKH

Hydraulically driven, dry-running HOFER piston compressors are designed for easy maintenance and allow a lubricant-free compression of non-corrosive gases, which are free from solid particles, such as hydrogen, helium, argon, nitrogen, carbon dioxide and ethylene.

The maximum discharge pressure of the standard design is approx. 14.500 psi (1.000 bar). For higher working pressures up to 65.250 psi (4.500 bar), special designs are available.

This compressor type is built in an easy to maintain construction. A piston packing can be replaced in approx. 10 to 30 minutes, depending on the compressor size.

Principle of working

The special construction and design of the piston packing allows to operate completely without the lubrication of these sealing elements at higher discharge pressures, although under normal circumstances such a lubrication is absolutely required.

The gas piston gets the required sealing and sliding properties by the design of the packing structure with the materials specially developed for this purpose. The gas space and the gas to be compressed are kept free from undesirable lubricants.

HOFER piston compressors of the TKH type series are preferably designed in a two-stage respectively one-stage double-acting design. The unit is driven by oil-hydraulics. The hydraulic cylinder is positioned between the first and second stage. A hydraulic pump with controllers alternating pressurises the hydraulic cylinder with the hydraulic oil. Proximity limit switches activate the stroke reversion.

Mixing of both media is excluded due to the separation of the hydraulic and the gas chamber and by use of double seals.

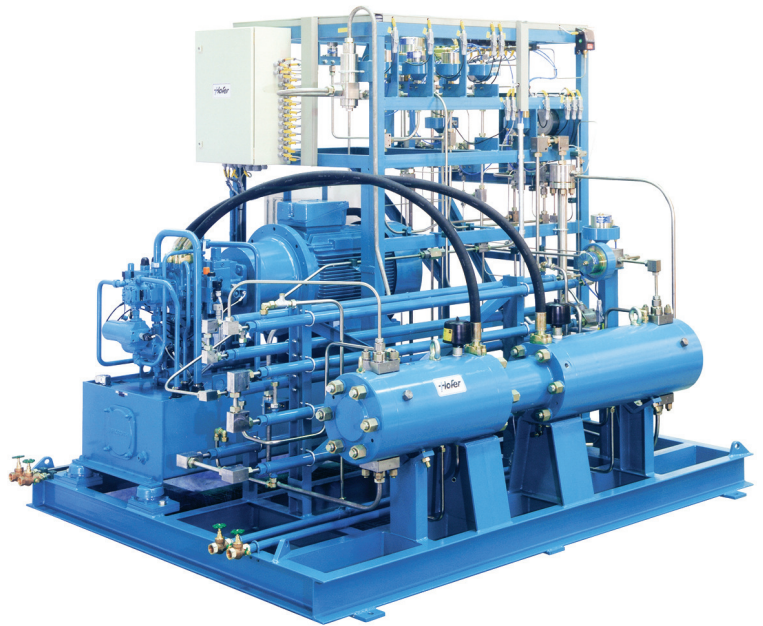

The force required for gas compression is generated by the oil pressure and the corresponding ratio of piston diameters.

The capacity is regulated by the piston speed (number of strokes) through varying of the flow rate of the pump. The frequency of strokes and, thus, the suction capacity of the compressor can be continuously regulated between 0% and 100% via a standard analogue signal.

Upon request, instruments for the detection of gas and oil leaks can be integrated at this point. This allows to permanently monitor the condition of gas- and oil-side seals. The gas which is compressed in the different stages is cooled by the respective downstream inter-stage and after cooler. Here, the temperature difference is approx. 10 K in relation to the cooling water inlet temperature. Usually, the hydraulic unit is also connected to this cooling circuit.

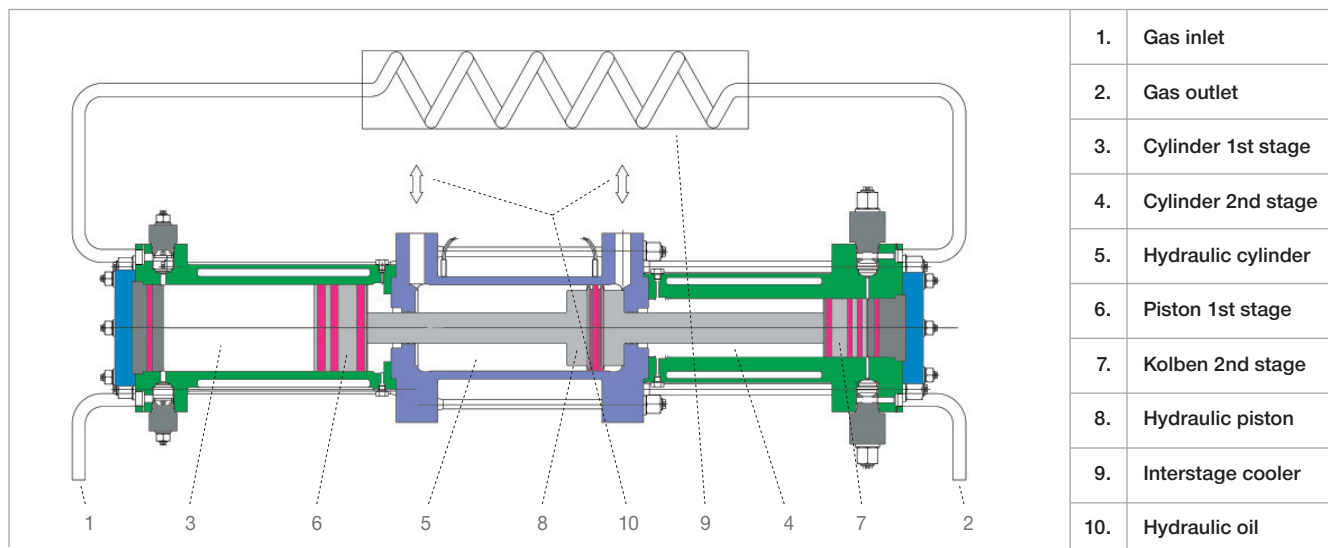

Type TKH for 65.250 psi (4.500 bar)

Installation of HOFER piston compressors in hazardous areas

For the use of the compressors in hazardous areas, two alternatives can be supplied:

1. Installation of the cylinder set in the hazardous area (zone 2 or 1) and installation of the hydraulic system in the non-hazardous area. The hydraulic oil unit is connected through a gastight wall.
2. Installation of the cylinder set and the hydraulic unit in the non-hazardous area (zone 2).

Capacity, compression ratios, pressure stages

The suction capacity of the compressor is determined by the suction pressure, the discharge pressure and the frequency of strokes. For different models please refer to the attached tables (other performance data upon request).

The stated driving powers apply to the maximum operating data.

Model designation

The main dimensions are encoded in the type designation for the Hofer TKH piston compressors:

Two-stage dry-running piston compressor with hydraulic drive unit TKH 52/36 -200 -50

Piston diameter first stage:	52 mm
Piston diameter second stage:	36 mm
Stroke:	200 mm
Max. allowable discharge pressure:	7.250 psi (500 bar)

One-stage double-acting compressor (e.g. booster) TKH 28/28 -80 -100

Piston diameter 1A. stage:	28 mm
Piston diameter 1B. stage:	28 mm
Stroke:	80 mm
Max. allowable discharge pressure:	14.500 psi (1.000 bar)

Equipment

The HOFER compressors of the TKH model series can be supplied as a compressor without accessories or turn-key as a complete operational unit with all necessary devices, fittings and instruments.

Acceptances and certifications

The standards and directives applicable in the European Community

- Directive for Machinery	98/37/EG
- Pressure Equipment Directive	97/23/EG
- ATEX Directive	94/9/EG
- Low Voltage Directive	93/68/EWG

as well as in above mentioned applicable standards are the basis of our construction and design.

Compliance with the applicable directives is confirmed by the conformity declaration respectively the manufacturer's declaration and the CE marking of the compressor.

US standards: For the American market, the applicable US regulations and standards are complied with.

Prior to delivery, each HOFER piston compressor is subjected to a test run under operating conditions for several hours. Upon request, the customer participates the test run.

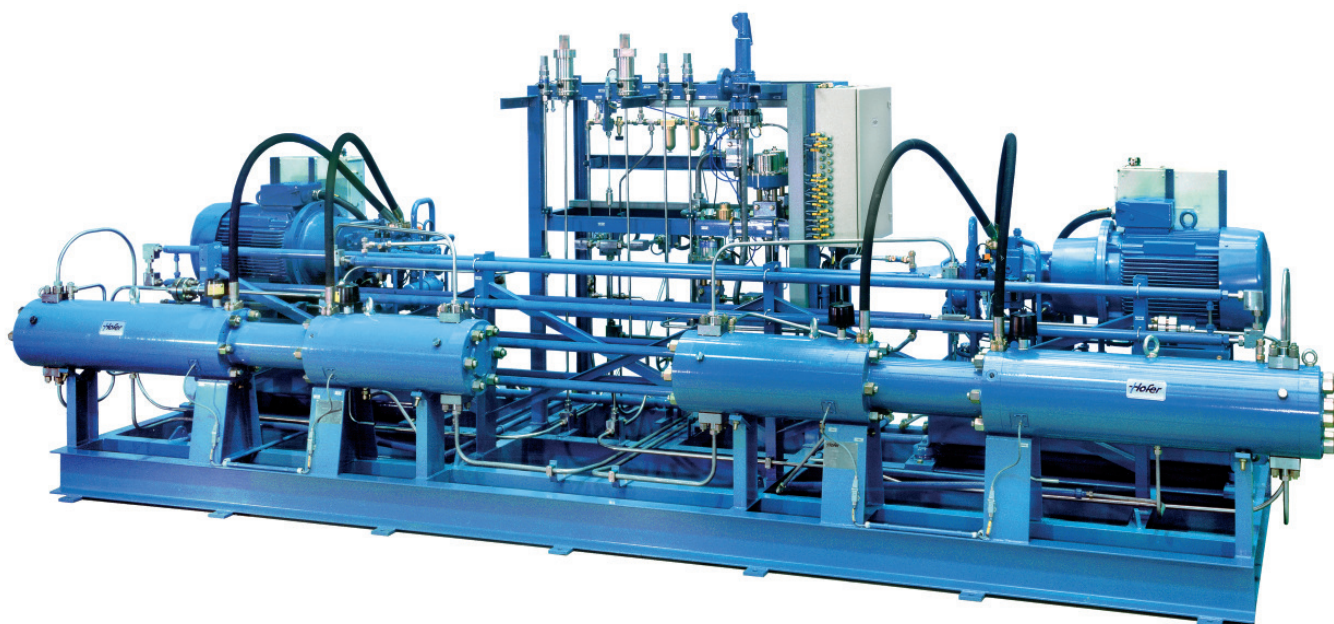

high tech in high pressure



HOFER diaphragm compressors

HOFER diaphragm compressors are hermetically sealed to the outside. Static seals guarantee a contamination-free compression of various gases such as nitrogen, hydrogen, helium, argon, ethylene, fluorine, hydrosulphide, chlorine gas, silane, NF_3 , etc. as well as gas mixtures.

The tightness amounts to 10^{-4} mbar l/s, in special designs up to 10^{-6} mbar l/s.

Diaphragm compressors are especially recommended for operation with toxic and explosive gases because this compressor type protect persons and environment. Gases of high purity can be compressed without any impurity and without losses.

HOFER high-pressure valves

DN 2 to DN 25, PN 250 (3.625 psi) to PN 10.000 (145.000 psi); manually-operated or pneumatically operated, opening or closing by spring force.



Serving Industry

HOFER compressors and valves are used in nearly every industry in which high-purity, rare, or hazardous gases are utilized. Some specific industries are:

- PTA plants
- Gas cylinder filling, gas blending and mixing systems
- Chemical, pharmaceutical and petrochemical plants
- Gas transfer, filling and off-loading of tube trailers
- Gases for electronics, semiconductor and fiber optics manufacturing
- Hydrogen filling stations
- Research and development
- Pressure boosting and high-pressure gas storage systems
- Space centers



Andreas Hofer Hochdrucktechnik GmbH

Ruhrorter Strasse 45
D-45478 Mülheim an der Ruhr
Germany

Phone +49-(0)208-46 99 6-0
Fax +49-(0)208-46 99 6-11
Web www.andreas-hofer.de
E-Mail info@andreas-hofer.de

Diaphragm
Compressors

Piston
Compressors

Pressurizing
Systems

Valves
Fittings

Hofer-
Service

certified to
ISO 9001
by TÜV CERT

certified to
PED Module H
by TÜV CERT

**HOFER dry-running piston compressors
hydraulically driven**

Ruhrorter Strasse 45
D-45478 Mülheim an der Ruhr, Germany

Phone +49-(0)208-4 69 96-0
Fax +49-(0)208-4 69 96-11

Web www.andreas-hofer.de
E-Mail info@andreas-hofer.de

A) Two-Stage Compressors

Model	Suction Pressure (min. allowable)		Capacity		Suction Pressure (max.)		Capacity		Discharge Pressure (max.)		Installed Motor Power kW
	psi	bar	scfm	Nm ³ /h	psi	bar	scfm	Nm ³ /h	psi	bar	
TKH 36/18-100-50	218	15	1,2	2	725	50	4,7	8	7.250	500	2
TKH 36/18-100-70	290	20	1,8	3	725	50	4,7	8	10.150	700	3
TKH 36/18-100-100	365	25	2,3	4	725	50	4,7	8	14.500	1000	4
TKH 52/26-200-50	218	15	5,3	9	725	50	18,2	31	7.250	500	7
TKH 52/24-200-70	290	20	6,5	11	725	50	17,7	30	10.150	700	11
TKH 52/22-200-100	365	25	7,6	13	725	50	17,1	29	14.500	1000	11
TKH 72/36-300-50	218	15	15,9	27	725	50	53,0	90	7.250	500	18
TKH 72/32-300-70	290	20	20,0	34	725	50	50,6	86	10.150	700	22
TKH 72/30-300-100	365	25	22,9	39	725	50	50,0	85	14.500	1000	30
TKH 100/50-500-50	218	15	44,1	75	725	50	147,0	250	7.250	500	45
TKH 100/46-500-50	290	20	54,1	92	725	50	144,0	245	10.150	700	75
TKH 100/42-500-100	365	25	64,7	110	725	50	141,3	240	14.500	1000	75
TKH 125/62-500-50	218	15	67,7	115	725	50	230,0	390	7.250	500	75
TKH 125/56-500-70	290	20	82,4	140	725	50	224,0	380	10.150	700	90
TKH 125/52-500-100	365	25	100,6	170	725	50	218,0	370	14.500	1000	110

B) Single Stage-Double Acting Boosters

Model	Suction Pressure (min. allowable)		Capacity		Suction Pressure (max.)		Capacity		Discharge Pressure (max.)		Installed Motor Power kW
	psi	bar	scfm	Nm ³ /h	psi	bar	scfm	Nm ³ /h	psi	bar	
TKH 16/16-40-100	3.625	250	3,5	6	7.250	500	6,5	11	14.500	1000	2
TKH 18/18-40-100	3.625	250	9,4	16	7.250	500	16,5	28	14.500	1000	4
TKH 28/28-80-100	3.625	250	18,8	32	7.250	500	33,0	56	14.500	1000	7
TKH 36/36-200-100	3.625	250	64,7	110	7.250	500	106,0	180	14.500	1000	17
TKH 52/52-200-100	3.625	250	124,0	210	7.250	500	235,0	400	14.500	1000	36

Alternative models upon request

high tech in high pressure