

Portable Compressors

# MOBILAIR M 115

With the world-renowned SIGMA PROFILE 

Flow rate 7.5 to 11.5 m<sup>3</sup>/min



M 115

# MOBILAIR M 115

## Powerful – efficient – clean

The powerful combination of the highly efficient KAESER SIGMA PROFILE rotary screw airend and an energy-saving Kubota engine (certified in accordance with EC directive 2004/26, Stage IIIB) provides impressive fuel efficiency and super-clean performance. Together with other innovative features, this compact powerhouse is yet another dependable and efficient compressed air partner from KAESER KOMPRESSOREN.

### Maximum versatility

The MOBILAIR M 115 can be specifically tailored to meet the needs of the relevant application thanks to the wide range of optional compressed air treatment components available. Moreover, the selection of chassis with run-on brake, as well as stationary models on skids or machine mountings, enables the M 115 to be perfectly adapted to suit the specific work environment.

### User-friendly

The ability to switch over manually from idling to full load operation ensures a reliable, gentle start when operating the unit in cold ambient conditions. If necessary, the compressor can shut itself down using the automatic monitoring system.

### Tough performer

The M 115 is well-equipped for continuous gruelling construction site duty, even under the harshest of conditions. Even the standard version is capable of operating in an ambient temperature range from -10° C to +45° C. The optional low-temperature version features engine coolant preheating, and synthetic cooling fluid is used for the airend.

### Made in Germany

MOBILAIR portable compressors are manufactured at KAESER's headquarters located in Coburg, Northern Bavaria. Equipped with the very latest technology, the recently modernised portable compressor plant boasts state-of-the-art equipment, including a TÜV (German Technical Inspection Agency) certified sound testing area for free-field sound level measurement, a complete powder-coating facility and efficient manufacturing logistics.

### Also available with generator option

The optional synchronous three-phase generator (IP 54) is available with a power of 8.5 or 13 kVa. According to power requirement, the brushless and maintenance-free generators can be switched over from continuous operation to energy-saving automatic start. If required, the generator control panel can be equipped with a lockable cover.



## Environmentally-sound powerhouse





# MOBILAIR M 115

**KAESER quality and efficiency for every need**



### Diesel particulate filter

Ensuring clean air not just in low emissions zones, a diesel particulate filter is installed as standard downstream from the Kubota drive engine. The M 115 is therefore certified in accordance with European standard EC RL 2004/26, Stage IIIB and even meets the stringent requirements of the Swiss Clean Air Act.

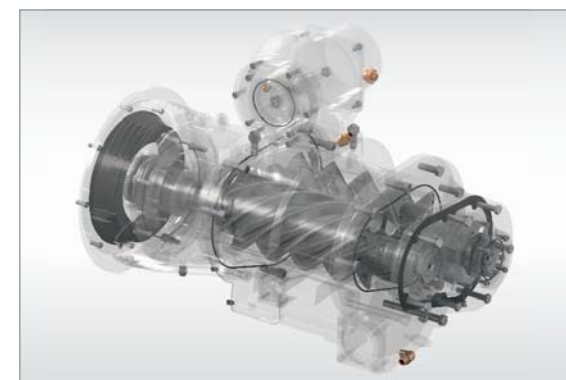

### SIGMA PROFILE air end

At the heart of every M 115 system lies a premium quality air end featuring KAESER's SIGMA PROFILE rotors. The air end's optimised flow characteristics enable it to deliver more air while using less energy.



### SIGMA CONTROL smart

This advanced compressor controller ensures optimised compressed air availability, fuel efficiency and exhaust gas reduction using state-of-the-art electronic motor management. Functions include operating mode display, intuitive user interface, monitoring and system diagnostics.



### Excellent accessibility, optimum serviceability

Thanks to intelligent component layout, all maintenance points are easily accessible via the large gull-wing doors, which makes service work fast and efficient. Optional custom service contracts are also available.



# MOBILAIR M 115

## Maximum versatility – optional accessories



### Cool and condensate-free

The compressed air is cooled to 7°C above ambient temperature. Installed at an angle, the compressed air aftercooler ensures frost-proof performance even at the coldest times of the year. The flow-optimised axial centrifugal separator reliably removes the condensate which is then evaporated.



### Dry compressed air

Machines with the optional compressed air aftercooler and return heating combination allow users to easily adjust the compressed air discharge temperature to meet the needs of the application.

**AIR**  
**QUALITY**

### Oiled or oil-free?

Depending on the application, the MOBILAIR 115 can be optionally equipped with a tool lubricator for oiled compressed air used to lubricate compressed air tools, or with a microfilter combination for blasting work requiring technically oil-free compressed air.

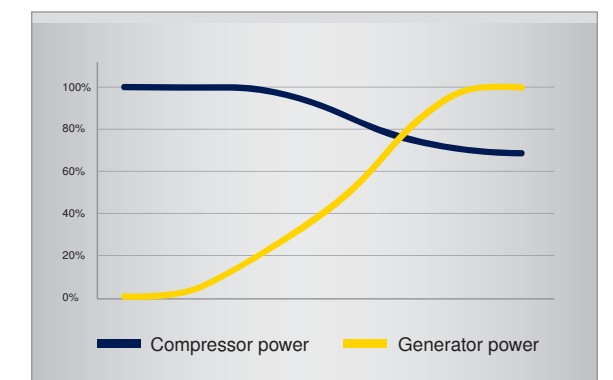

### Generator

The advanced SIGMA CONTROL compressor controller ensures optimised compressed air availability and fuel efficiency using the very latest electronic motor management.



## Optional equipment

### Sealed floor plan

The sealed floor pan catches all liquids and therefore prevents potential soil contamination. All drainage holes are sealed with screw plugs.

### Pressure variants

Models are available in various pressure versions ranging from 7 to 14 bar. Pressure can easily be adjusted in steps of 0.5 bar from 5 bar to 0.5 bar above nominal pressure using the SIGMA CONTROL smart's arrow keys. The pressure adjustment feature can also be electronically disabled to safeguard parameter settings against unintentional changes.

### Suitable for refinery use

A certified spark arrestor is available for refinery applications. In addition, the engine shut-off valve automatically shuts the unit down upon intake of combustible gases.

### GPS/GSM monitoring

The MOBILAIR fleet management on-line tool provides operators with a range of data including working pressure, fuel tank fill level, service alerts, location and machine load. The system optimises service processes by sending notifications regarding e.g. fault causes and upcoming scheduled maintenance measures.



## Compressed air treatment systems

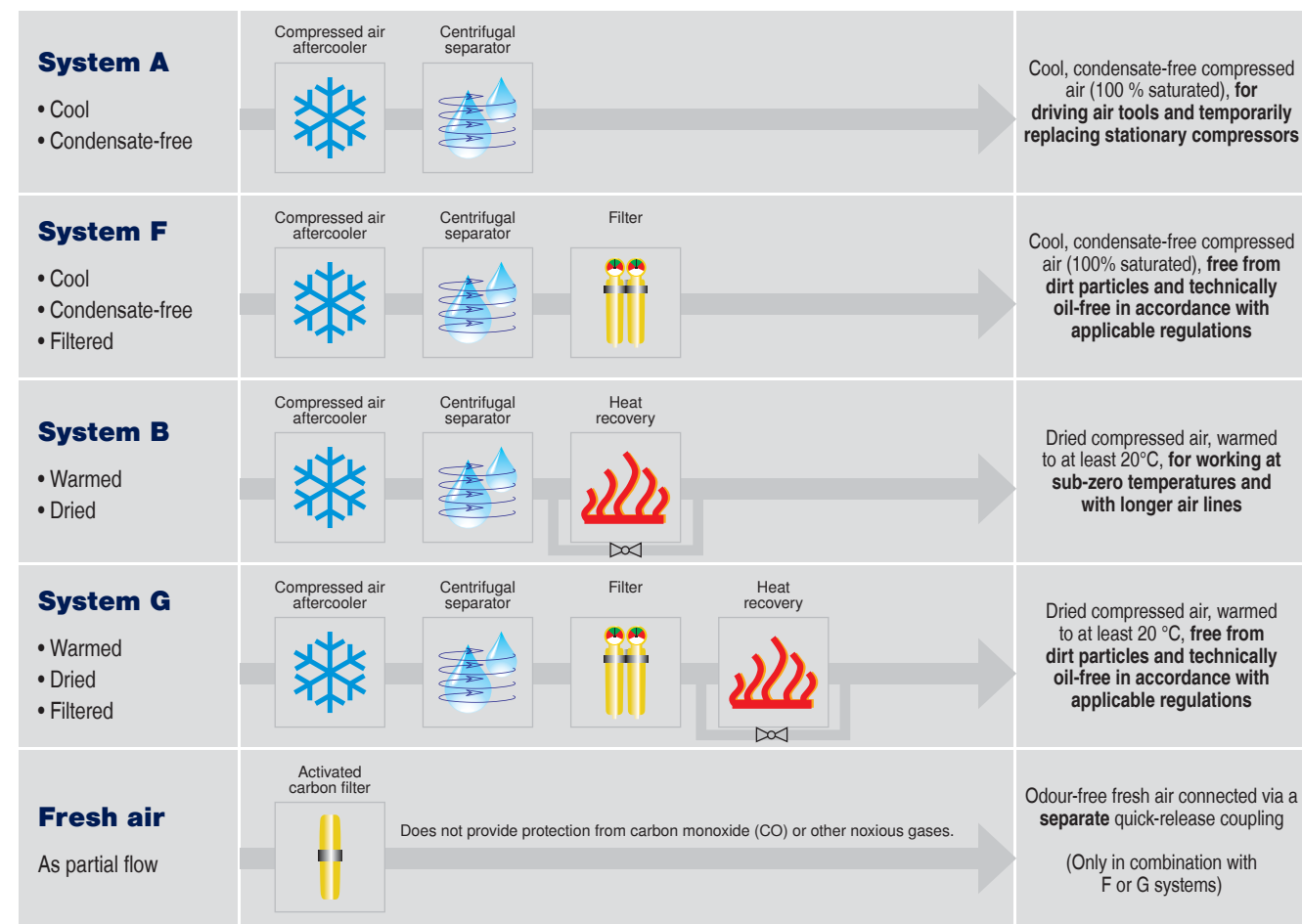

## Dimensions

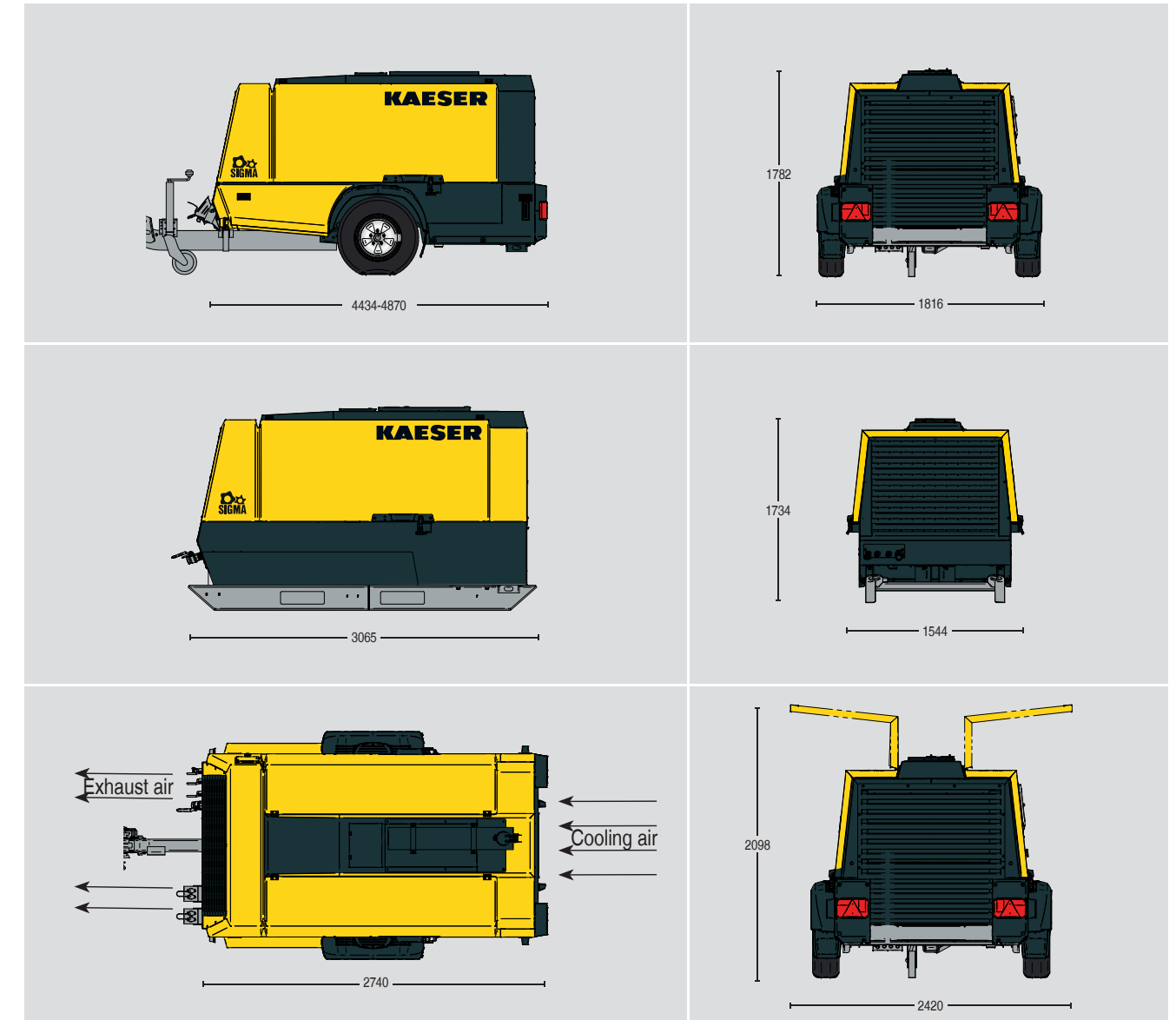

## Technical specifications

| Model | Compressor                        |                            | 4-cylinder diesel engine (Water-cooled) |        |                         |                           | Package                 |  |  |   |                          |
|-------|-----------------------------------|----------------------------|---|--------|-------------------------|---------------------------|-------------------------|--|--|---|--------------------------|
|       | Flow rate<br>m <sup>3</sup> /min  | Working pressure<br>bar    | Make                                    | Model  | Rated motor power<br>kW | Speed at full load<br>rpm | Fuel tank capacity<br>l | Operational weight<br>kg <sup>1)</sup> | Sound power level<br>dB(A) <sup>2)</sup> | Sound pressure level<br>dB(A) <sup>3)</sup> | Compressed air outlet    |
| M115  | 11.5<br>10.5<br>9.7<br>8.4<br>7.5 | 7<br>8.6<br>10<br>12<br>14 | Kubota                                  | V 3800 | 85                      | 2600                      | 145                     | 1850                                   | <99                                      | 70  | 3 x G 3/4<br>1 x G 1 1/2 |

<sup>1)</sup> Applies to standard unit without air treatment with overrun brake chassis

<sup>2)</sup> Guaranteed sound power level as per 2000/14/EC

<sup>3)</sup> Surface sound pressure level as per ISO 3744 (r: 10m)

# KAESER – The world is our home

As one of the world's largest manufacturers of rotary screw compressors, KAESER KOMPRESSOREN is represented throughout the world by a comprehensive network of branches, subsidiary companies and authorised partners in over 100 countries.

With innovative products and services, KAESER KOMPRESSOREN's experienced consultants and engineers help customers to enhance their competitive edge by working in close partnership to develop progressive system concepts that continuously push the boundaries of performance and compressed air efficiency. Moreover, the decades of knowledge and expertise from this industry-leading system provider are made available to each and every customer via the KAESER group's global computer network.

These advantages, coupled with KAESER's worldwide service organisation, ensure that all products operate at the peak of their performance at all times and provide maximum availability.

