

SERIES  
**AIR CENTRE**

ROTARY VANE COMPRESSORS FROM 7,5 TO 250 kW



# SERIES AIR CENTRE



## About Us

Ing. **Enea Mattei SpA** is an Italian company that has been producing air compressors since 1919. Over the years, the company has continually evolved and is today one of the world's foremost companies in the compressed air sector and the leader in the production of rotary vane compressors.

Behind the success of Mattei are the choices the company has made in terms of design, production and marketing, driven by the results of its continual and in-depth research and development programmes.

During these years of continual change, Mattei has been able to adapt to the requirements of the market and through the results of its research has created products that are always innovative and technologically advanced.



## Certified quality

Quality as an integral part of all company functions and constant improvement of all production processes so as to always guarantee the maximum level of reliability and satisfaction. This, in brief, is the value and the meaning of **Mattei's** operational philosophy. A way of approaching the market and customers that makes **Mattei** an absolute point of reference in the compressed air sector.

Since 1994, **Mattei** has been operating with a Quality System certified by the DNV Institute under UNI EN ISO 9001 regulations.



# Simply different The compressor that makes a difference

## MATTEI'S COMPRESSORS

Mattei's rotary vane air compressors are the result of continuous innovation and advanced design capabilities. The low rotational speed of the compressor unit found only in vane technology, the high volumetric efficiency and the complete absence of roller or thrust bearings, result in energy savings of **over 15%** compared to other rotary compressors.

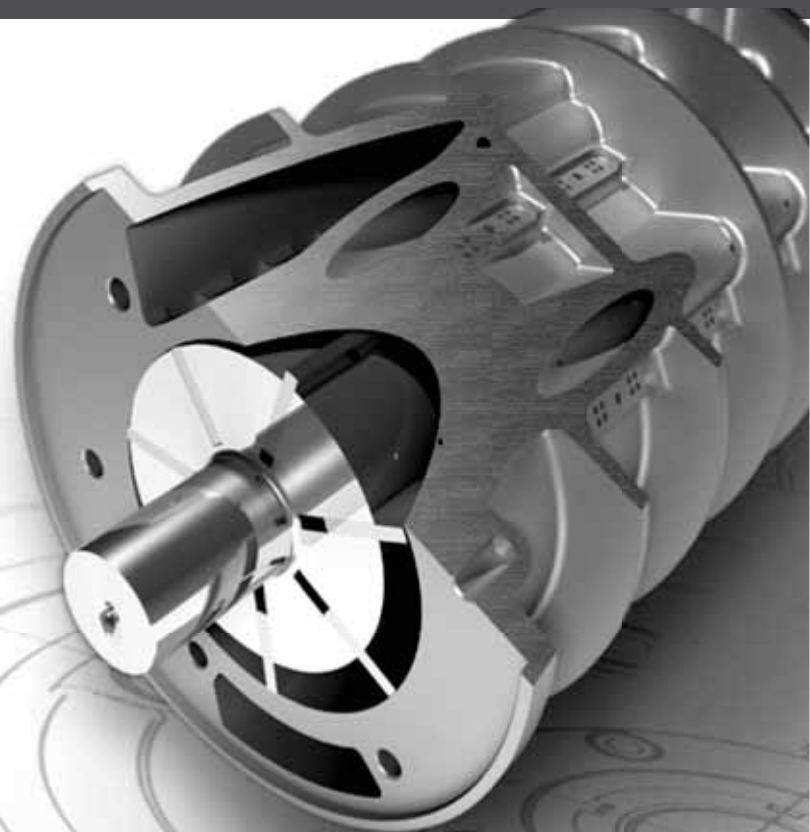

### EFFICIENCY 1:1

All Mattei's compressors have a 1:1 ratio between the electric motor speed and that of the airend. This means greater energy efficiency and higher performances.

Compared to other technologies, rotary vane compressors guarantee a superior internal air seal, together with a consistent and long lasting performance.

### SAFETY / RELIABILITY

The integrated design, direct coupling, low rotational speed and the limited number of moving parts ensure Mattei's rotary vane air compressors remain safer, more durable and therefore more reliable over time.

### LOW OPERATING COSTS: LOW MAINTENANCE

Mattei's rotary vane compressors are designed to reach 100,000 hours life without the need to replace any blades or other metal parts.

The long operating life of a Mattei compressor is assured by high quality machining which is the essence of rotary vane air compressors.

### SIMPLICITY

Mattei's rotary vane air compressors are quiet and can be located almost anywhere. They are quickly installed and take up a limited amount of space.

Their accessible design makes maintenance operations simple and straightforward.

OTHER COMPRESSORS  
MAINTENANCE

MATTEI'S COMPRESSORS  
MAINTENANCE

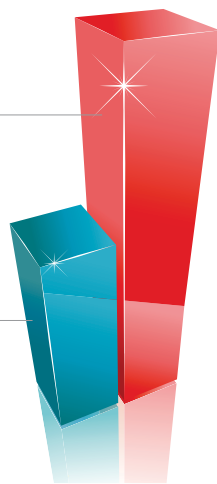

### QUALITY OF THE AIR

All Mattei's compressors are fitted with a generously sized filtering system, which guarantees quality compressed air suitable for any use. Mattei's very efficient, multi-stage oil separation system produces an exceptionally low lubricant carry-over.



# SERIES AIR CENTRE

## Series Air Centre Rotary Vane Compressors

Mattei's Air Centre series compressors are complete and efficient machines that are ideal for any type of industrial application.

### DIRECT COUPLING

Mattei has always produced compressors in which the electric motor, which turns at a speed of only 1,500 rpm, is directly coupled to the compression unit by means of a flexible joint. This direct, in-line coupling results in considerable energy saving as there are no losses due to the presence of pulley wheels and drive belts.



### AUTOMATIC FLOW RATE CONTROL

As well as the classic "ON/OFF OPERATION" mode, all of the models, from the AC 7 to the AC 90, are fitted with the special modulating proportional intake valve which allows air supply at a constant pressure and even offers the possibility of working without an air storage tank.

### DURABLE AND QUIET

AIR CENTRE compressors are epoxy powder coated and corrosion and scratch resistant. In addition they are lined internally with a thick layer of high-quality soundproof material and equipped with a high efficiency cabinet pre-filter. This filtering device prevents the radiator and main air filter from premature clogging caused by impurities in the intake air, thus providing additional cost savings.

### SIMPLE AND ACCESSIBLE MAINTENANCE

Large hinged doors and easily removable panels allow complete and easy accessibility for all maintenance and intervention operations. The compressor requires no special foundations and its base has suitable lifting points for ease of installation.

### COMPRESSOR AND DRYER: ALL-IN-ONE

The plus version includes the integrated installation of a direct expansion refrigeration dryer, which is air cooled and filled with environmentally friendly gas. The combination of a Mattei rotary vane air compressor with an integrated dryer and where applicable mounted on an air receiver is the ideal solution for a complete and compact system.



## Operating principle



**Maximum efficiency of the air compression process, excellent reliability and low running costs; are just some of the key benefits that rotary vane technology can offer.**

The vane compressor is a volumetric rotary compressor that consists of a stator cylinder in which a rotor is mounted off-centre but parallel to its sides. The rotor has slots in which the vanes are free to slide: centrifugal force keeps them in contact with the sides of the stator during rotation.

The rotary vane compressor, thanks to its **simple construction**, offers remarkable advantages, first among them being **greater volume yield** because the vanes are in constant contact with the inner wall

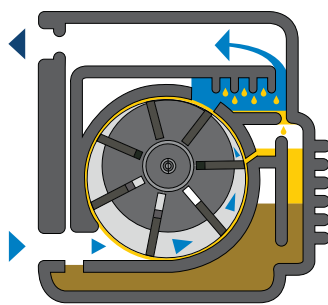

of the stator and form a perfectly airtight seal with no leaks along the wall thanks to a continuous film of oil. In this type of compressor no axial thrust is generated so the side surfaces of the rotor are not subject to wear and thus no rotating bearings or thrust bearings are needed. The vanes, too, because of the special way they are made have practically **unlimited life**.

Behind the success of Mattei compressors there is thus **extreme reliability, long life, quiet operation and simplicity of maintenance**. Design is important too: compactness and clean lines, together with harmonious shapes, give Mattei compressors an image of robustness and ease of use.

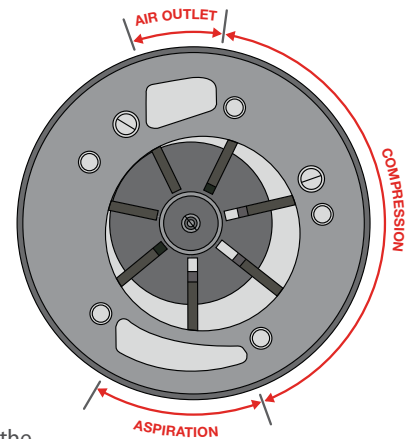

### SOFT - START

Motor soft starter allows a reduction of the load and torque in the power train and electrical current surge of the motor during start-up.

This reduces the mechanical stress on the motor and shaft, as well as the electrodynamic stresses on the attached power cables and electrical distribution network, extending the lifespan of the system.

### A HIGH EFFICIENCY OIL SEPARATION

The separation of the lubrication oil from the compressed air takes place in multiple stages. A first separation occurs in the oil chamber as the air passes through a labyrinth path, then it continues at the separator inlet (before the filter) where the air flow slows down passing through a series of directional variations, and finally through the coalescing filter.

Due to this superior separation system the oil carry over is extremely low, leading to improved separator life, greater protection for the application and reduced operating costs.



# SERIES AIR CENTRE



## Series 500 QC/QCS 7 > 15s

Rated power:	7,5 to 15 kW
F.A.D.:	0,96 to 1,97 m <sup>3</sup> /min
Max. working pressure:	8/10/13 bar
Sound pressure level:	65 dB(A)
Hz:	50

Rated power:	7,5 to 11 kW
F.A.D.:	1,18 to 2,11 m <sup>3</sup> /min
Max. working pressure:	8/10/13 bar
Sound pressure level:	67 dB(A)
Hz:	60



## Series 1000 QC 15 > 30s

Rated power:	15 to 30 kW
F.A.D.:	1,87 to 4,19 m <sup>3</sup> /min
Max. working pressure:	8/10/13 bar
Sound pressure level:	67-68 dB(A)
Hz:	50

Rated power:	15 to 22 kW
F.A.D.:	2,4 to 3,95 m <sup>3</sup> /min
Max. working pressure:	8/10/13 bar
Sound pressure level:	69 dB(A)
Hz:	60



## Series 2000 QC 30 > 45

Rated power:	30 to 45 kW
F.A.D.:	3,67 to 8,28 m <sup>3</sup> /min
Max. working pressure:	8/10/13 bar
Sound pressure level:	66 dB(A)
Hz:	50

Rated power:	30 to 45 kW
F.A.D.:	4,9 to 9,9 m <sup>3</sup> /min
Max. working pressure:	8/10/13 bar
Sound pressure level:	68 dB(A)
Hz:	60





## Series 4000

### QC 55 > 90

Rated power:	55 to 90 kW
F.A.D.:	8,37 to 16,79 m <sup>3</sup> /min
Max. working pressure:	8/10/13 bar
Sound pressure level:	68 dB(A)
Hz:	50



## Series 6000

### QC 110 > 132

Rated power:	110 to 132 kW
F.A.D.:	16,2 to 24,47 m <sup>3</sup> /min
Max. working pressure:	8/10/13 bar
Sound pressure level:	69 dB(A)
Hz:	50



## Series 8000

### QC 160 > 250

Rated power:	160 to 250 kW
F.A.D.:	24,4 to 44 m <sup>3</sup> /min
Max. working pressure:	8/10/13 bar
Sound pressure level:	75 dB(A)
Hz:	50



# Air Centre CONTROLLERS



## MAESTRO<sup>XS</sup>

to have everything  
under control

With a view to energy saving, the communication inside a compressor room plays a decisive role.

It is absolutely essential to manage, control and immediately intervene in the operation of the system in order to prevent waste and unnecessary energy consumption.

For this reason, all of Mattei's Air Centre compressors are fitted as standard with a microprocessor command and control device: Maestro<sup>XS</sup>.

## Microprocessor control system

Maestro<sup>XS</sup> is programmable controller, which regulate the compressor's operation and adapt this to the specific requirements of the air distribution system. It has different programming levels and special options of controlling and analysing the operation and faults. Advanced programming and analysis levels are protected by digital codes to avoid unintentional tampering. Maestro<sup>XS</sup> has an integrated memory module that stores the operational settings and data in case of a power failure.

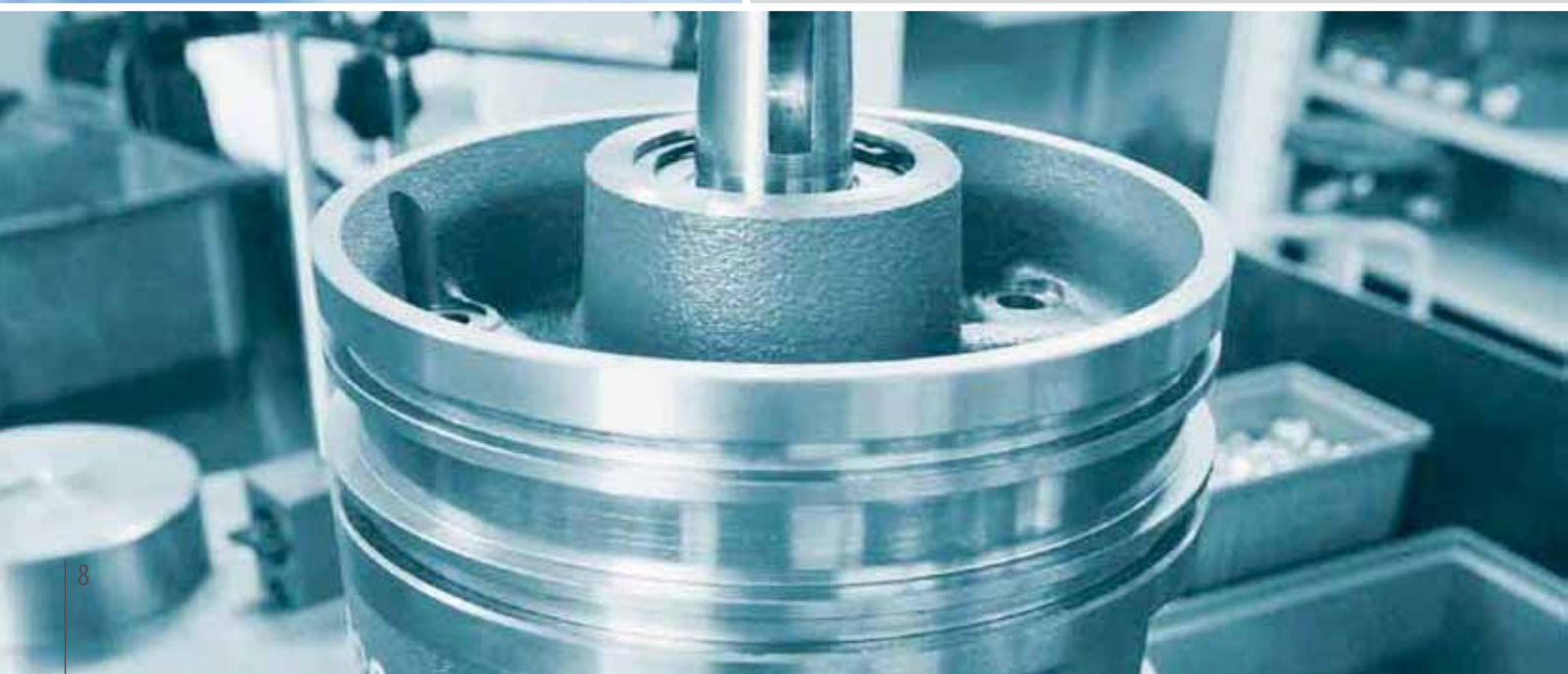



## MAESTRO<sup>xs</sup>: Features and functions



- Ergonomic control panel with quick access keys to main menus.
- Menus access keys, start, stop and reset led keys.
- Semi-graphic LCD display with illuminated text.
- 24 Vdc digital inputs.
- Digital dry contacts output up to 230 Vac and up to 24 Vdc.
- Interfaces:
  - RS485 for intercommunication with other MAESTRO devices.
  - RS485 (optional) to communicate with the supervising PC and network.
- Analogue data display (line pressure, chamber pressure, oil temperature, outgoing air temperature) and general data (alarms, operating messages, machine state, maximum and minimum pressure, last start and stop times).
- Hour counter to display the enabled, working and load times and maintenance notices.
- Events database to store alarms and blocks, with alarm intervention indication, alarm intervention time, machine state.
- Multi-language user interface.
- Weekly and hourly programmable start and stop times.
- Immediate reading of the compressor operating data on the display.
- Basic and advanced parameters programming for an optimal operation of the compressor.
- Storage of up to 20 malfunctioning events.
- Storage of the last 20 programme modifications.
- Control of the integrated dryer.
- Machine start and stop remote control.
- The feedback (as standard), through dry contacts, of the following machine states: enabled compressor, working compressor, loaded compressor, blocked compressor.



# Air Centre CONTROLLERS

## CONCERTO: Complete control and absolute flexibility



Numerous compressor stops and starts, energy wastage and wide variations in the compressor operation represent common problems in many compressed air systems.

Concerto is Mattei's state-of-the-art compressed air management system, designed to satisfy any requirement of a compressed air user, regardless of the type of compressor installed. By the use of customisable functions the device allows the simultaneous command and control of **up to 16 compressors**, maintains a tight energy-saving pressure dead-band, limiting the idle running times and optimising the customer's choice. Concerto enables **energy savings of over 35%**.



### IMMEDIATE SAVING

Regardless of the compressors combination and model, Concerto always selects the most economical configuration, maximising the plant efficiency.

Concerto controller extends the life of your compressors, guaranteeing the smallest number of motor start ups, and eliminating idle running times almost completely.

### FUNCTIONALITIES

Concerto requires only a few configuration parameters, to allow the combination of differently performing compressors to synchronise their compressed air production with the consumption demand.

A clear display facilitates the system programming operations, making them easy and intuitive.

### CONTROL VIA PC

The main parameters, failure signals, maintenance intervals and energy consumptions can be directly displayed on a PC via a normal web server. This way the equipment can always be easily monitored and controlled in order to minimise unplanned events.

### GLOBAL MANAGEMENT

Dryers, filters and condensate treatment accessories can be directly connected to the system via digital inputs. In the same way analogue output sensors can be connected, in order to monitor the entire compressed air system.

Due to this Concerto provides an extremely wide range of information regarding the plant management, which is also viewable via web server.

Concerto also manages and controls variable speed compressors, fitted with an inverter, ensuring that they remain within their maximum efficiency range.

## QUARTETTO

When a production process requires variable amounts of compressed air or it is necessary to avoid any machine downtime, a controller optimises the compressed air system management. **Quartetto**, obtained through a programmable controller, can control operation of more compressors, **up to max. 4 units**, provided these are arranged with a remote start-stop control. It is not essential to drive exclusively Mattei compressors. **Quartetto** can meet the line air demand and the working load for each compressor in the most efficient way and reducing the energy absorption.

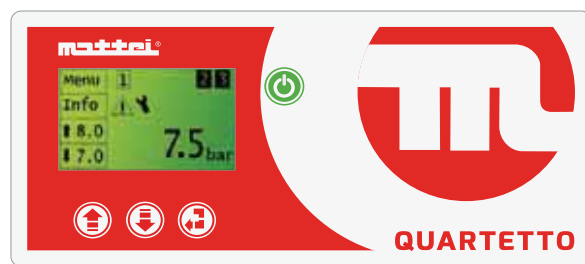

### OPERATING MODE

- *Balance hours: for installation consisting of compressors of the same power where you want to use the machines alternately and obtain even wear*
- *Priority: for installation where the installer / end user decides the priority of the compressor (ie the sequence of action) by assigning them a number*
- *Smart: operating principle to obtain the best performance by optimizing the power consumption (saving) for a plant always reactive to any changes in the pressure*

### Hardware

- ▶ Master controller with LCD display (2 lines, 16 characters) and LED;
- ▶ 230 Vac power supply;
- ▶ 4 digital outputs;
- ▶ Probe signal 4 ÷ 20 mA.

### Software

- ▶ Up to 4 different compressors (piston, screw vane, scroll,...);
- ▶ Weekly programming;
- ▶ Display of information in different languages;
- ▶ Sends any reports of system irregularities via SMS, e-mail or fax.





# SERIES AIR CENTRE

## Energy recovery from compressed air

In a lubricated and air-cooled compressor, about 80% of its absorbed power is wasted as heat in the oil. The heat absorbed by the oil during the air compression process is transferred to the air flow, that goes through the cooler and is dispersed to the atmosphere.

The mechanical energy used for compression is wasted as follows:

- about 80% for oil cooling;
- about 10-12% transferred to the compressed air as heat;
- about 2-3% in compressed air as energy;
- the rest due to heat radiation.

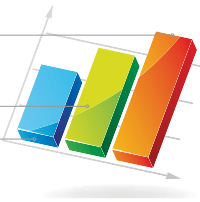

Mattei offers for its compressors a heat recovery system that allows water to be heated for industrial process or sanitary use.



The "Heat Recovery" kit is totally integrated into the oil cooling circuit, making the unit independent from the oil temperature control and protected from any possible malfunctions, such as water flow reduction and overheating.

## How much can you save by recovering heat?



The possibility to use the energy recovered as hot water during an entire year depends on the use you make of it.

Up to 80% of the recovered heat can be used in your industrial building to produce hot sanitary water or for space heating.

It is even possible to recover up to 100% of the thermal energy if there is an industrial process that requires heat.

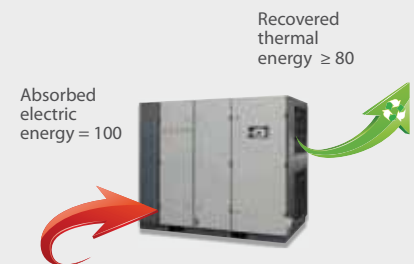

## Total quality management



### TOTAL QUALITY MANAGEMENT

Mattei considers quality as an essential value that represents the key factor to develop a positive relationship between the culture and performance of one's company. Innovative management software, developed solely for Mattei and technologically advanced manufacturing equipment, such as robotic machining centres and high precision machine tools, are at the heart of the advanced technical and quality levels of Mattei's products.

### 3D QUALITY CONTROL

The quality check of manufacturing tolerances occurs constantly via three dimensional measurement machines. This ensures the compliance of our products with the highest quality standards.

### COMPREHENSIVE TESTS

Before leaving our factory any Mattei compressor has already undergone various extensive and in-depth testing procedures, during which it has been checked and tested in different operating conditions. All the electric, mechanical and performance information are recorded via a wireless data detection system.

### HIGH TECHNOLOGY MANUFACTURING MACHINERY

The manufacturing of compression units and blades is made through modern robotic machining centres. The parts assembly is carried out by specialised staff and in accordance with strictly controlled operating procedures, specified by Mattei's quality management.

## Always caring about our customers' requirements



### WORLDWIDE CONSULTANCY AND ASSISTANCE

Mattei operates worldwide with its sales and assistance network, providing a wide service range.

By purchasing a Mattei compressor you can rely on a qualified after-sales service, able to answer any request for assistance in very short time scales.



## Mattei original spare parts and lubricants

Mattei Original Spare Parts and Mattei lubricants are made to very high design standards and conform to precise technical specifications. Only Mattei original spare parts allow you to be sure of maintaining over time the same levels of performance, reliability and safety of your Mattei product.

- Mattei Original Spare Parts are indispensable for the efficiency of your compressed air equipment
- Parts are always available in stock
- Quality tested and conforming to manufacturer specifications
- Suitable for Mattei's recommended maintenance intervals











## MIEM: Mattei Intelligent Energy Management

The cost to produce a fixed quantity of compressed air greatly depends on the efficiency of the compression system. To obtain potentially significant energy savings it is important to identify the minimum working pressure and demand profile required for a plant's compressed air supply. The MIEM system allows Mattei to check the suitability of a currently installed compressed air plant and to verify any possible opportunities to improve its efficiency. Thanks to specifically developed software, Mattei's technicians are able to evaluate the customer's current air consumption profile and to estimate the relative energy consumption. In addition the MIEM analysis allows Mattei to simulate the optimum energy solution via a computer, often providing potential savings of 40%.









# Technical data

## 50 Hz - 400V/3

	 Model	 8 bar 115 psig L		 10 bar 150 psig H		 13 bar 175 psig HH		 Sound pressure level	 Power		 Air receiver	 Length Width Height						 Weight																	
		m <sup>3</sup> /min		cfm		m <sup>3</sup> /min			cfm			m <sup>3</sup> /min		cfm		db(A)		kW		hp		l		mm		inch		mm		inch		kg		lbs	
		m <sup>3</sup> /min	cfm	m <sup>3</sup> /min	cfm	m <sup>3</sup> /min	cfm		m <sup>3</sup> /min	cfm		db(A)	kW	hp	l	mm	inch	mm	inch	mm	inch	kg	lbs												
500	AC 7	1,38	48,7	1,15	40,6	0,96	33,9	65	7,5	10	-	1250	49,3	610	24,0	1040	41,0	220	484																
	AC 11	1,97	69,6	1,7	60	1,35	47,7	65	11	15	-	1250	49,3	610	24,0	1040	41,0	240	528																
	AC 15s	-	-	1,95	68,9	1,83	64,6	65	15	20	-	1250	49,3	610	24,0	1040	41,0	260	572																
	AC 7 PLUS	1,38	48,7	1,15	40,6	0,96	33,9	65	7,5	10	-	1250	49,3	610	24,0	1040	41,0	245	539																
	AC 11 PLUS	1,97	69,6	1,7	60	1,35	47,7	65	11	15	-	1250	49,3	610	24,0	1040	41,0	265	583																
	AC 15s PLUS	-	-	1,95	68,9	1,83	64,6	65	15	20	-	1250	49,3	610	24,0	1040	41,0	285	627																
	ACS 7	1,38	48,7	1,15	40,6	0,96	33,9	65	7,5	10	270	1530	60,3	750	29,6	1540	60,7	310	682																
	ACS 11	1,97	69,6	1,7	60	1,35	47,7	65	11	15	270	1530	60,3	750	29,6	1540	60,7	330	726																
	ACS 15s	-	-	1,95	68,9	1,83	64,6	65	15	20	270	1530	60,3	750	29,6	1540	60,7	350	770																
	ACS 7 PLUS	1,38	48,7	1,15	40,6	0,96	33,9	65	7,5	10	270	1530	60,3	750	29,6	1540	60,7	335	737																
	ACS 11 PLUS	1,97	69,6	1,7	60	1,35	47,7	65	11	15	270	1530	60,3	750	29,6	1540	60,7	355	781																
ACS 15s PLUS	-	-	1,95	68,9	1,83	64,6	65	15	20	270	1530	60,3	750	29,6	1540	60,7	375	825																	
1000	AC 15 (*)	2,7	95,3	2,2	77,7	1,87	66	67	15	20	-	1500	59,1	800	31,5	1200	47,3	460	1012																
	AC 18 (*)	3,28	115,8	2,64	93,2	2,26	79,8	67	18,5	25	-	1500	59,1	800	31,5	1200	47,3	460	1012																
	AC 22 (*)	3,75	132,4	3,2	113	2,57	90,7	67	22	30	-	1500	59,1	800	31,5	1200	47,3	465	1023																
	AC 30s (*)	-	-	4,19	148	3,55	125,4	68	30	40	-	1500	59,1	800	31,5	1200	47,3	515	1133																
	AC 15 PLUS (*)	2,7	95,3	2,2	77,7	1,87	66	67	15	20	-	1500	59,1	800	31,5	1200	47,3	500	1100																
	AC 18 PLUS (*)	3,28	115,8	2,64	93,2	2,26	79,8	67	18,5	25	-	1500	59,1	800	31,5	1200	47,3	500	1100																
	AC 22 PLUS (*)	3,75	132,4	3,2	113	2,57	90,7	67	22	30	-	1500	59,1	800	31,5	1200	47,3	505	1111																
AC 30s PLUS (*)	-	-	4,19	148	3,55	125,4	68	30	40	-	1500	59,1	800	31,5	1200	47,3	555	1221																	
2000	AC 30 (**)	5,62	198,4	4,67	164,9	3,67	129,6	66	30	40	-	1830	72,1	960	37,8	1670	65,8	800	1760																
	AC 37 (**)	6,8	240,1	5,65	199,5	4,8	169,5	66	37	50	-	1830	72,1	960	37,8	1670	65,8	830	1826																
	AC 45 (**)	8,28	292,4	7	247,2	5,85	206,6	66	45	60	-	1830	72,1	960	37,8	1670	65,8	940	2068																
	AC 30 PLUS (**)	5,62	198,4	4,67	164,9	3,67	129,6	66	30	40	-	1830	72,1	960	37,8	1670	65,8	900	1980																
	AC 37 PLUS (**)	6,8	240,1	5,65	199,5	4,8	169,5	66	37	50	-	1830	72,1	960	37,8	1670	65,8	930	2046																
4000	AC 45 PLUS (**)	8,28	292,4	7	247,2	5,85	206,6	66	45	60	-	1830	72,1	960	37,8	1670	65,8	1040	2288																
	AC 55 (**)	10,67	376,8	9,5	335,5	8,37	295,6	68	55	75	-	2420	95,3	1245	49,1	1890	74,5	1680	3696																
	AC 75 (**)	14,32	505,6	12,66	447	11,18	394,8	68	75	100	-	2420	95,3	1245	49,1	1890	74,5	1780	3916																
	AC 90 (**)	16,79	592,9	14,12	498,6	12,49	441	68	90	125	-	2420	95,3	1245	49,1	1890	74,5	1880	4136																
	AC 55 PLUS (**)	10,67	376,8	9,5	335,5	8,37	295,6	68	55	75	-	2420	95,3	1245	49,1	1890	74,5	1840	4048																
	AC 75 PLUS (**)	14,32	505,6	12,66	447	11,18	394,8	68	75	100	-	2420	95,3	1245	49,1	1890	74,5	1940	4268																
6000	AC 90 PLUS (**)	16,79	592,9	14,12	498,6	12,49	441	69	90	125	-	2420	95,3	1245	49,1	1890	74,5	2040	4488																
	AC 110 (**)	21,35	753,9	17,65	623,2	16,2	572	69	110	150	-	2350	92,6	1390	54,8	1980	78,0	2500-2400(1)	5500-5280(1)																
	AC 132 (**)	24,47	864,1	21,95	775,1	18,65	658,5	69	132	175	-	2350	92,6	1390	54,8	1980	78,0	2790	6138																
	AC 110 PLUS (**)	21,35	753,9	17,65	623,2	16,2	572	69	110	150	-	2350	92,6	1390	54,8	1980	78,0	2800-2700(1)	6160-5940(1)																
8000	AC 132 PLUS (**)	24,47	864,1	21,95	775,1	18,65	658,5	69	132	175	-	2350	92,6	1390	54,8	1980	78,0	3090	6798																
	AC 160 (**)	29,3	1034,6	26,6	939,3	24,4	861,6	75	160	200	-	2700	106,4	1780	70,1	2240	88,3	4050	8910																
	AC 200 (**)	36,7	1295,9	30,85	1089,3	28,8	1016,9	75	200	250	-	2700	106,4	1780	70,1	2240	88,3	4600-4470(2)	10120-9834(2)																
	AC 250 (**)	44	1553,7	40,7	1437,1	33,65	1188,2	75	250	350	-	2700	106,4	1780	70,1	2240	88,3	4800-4490(1)	10560-9878(1)																



## 60 Hz - 460V/3

	Model					 Sound pressure level	 Power	 Air receiver							 Weight				
		8 bar 115 psig L		10 bar 150 psig H					13 bar 175 psig HH		Length		Width			Height			
		m <sup>3</sup> /min	cfm	m <sup>3</sup> /min	cfm				m <sup>3</sup> /min	cfm	db(A)	kW	hp	l		mm	inch	mm	inch
500	AC 7	1,39	49,1	1,2	42,4	1,18	41,7	67	7,5	10	-	1250	49,3	610	24,0	1040	41,0	220	484
	AC 11	2,11	74,5	1,87	66	1,65	58,3	67	11	15	-	1250	49,3	610	24,0	1040	41,0	240	528
	AC 7 PLUS	1,39	49,1	1,2	42,4	1,18	41,7	67	7,5	10	-	1250	49,3	610	24,0	1040	41,0	245	539
	AC 11 PLUS	2,11	74,5	1,87	66	1,65	58,3	67	11	15	-	1250	49,3	610	24,0	1040	41,0	265	583
	ACS 7	1,39	49,1	1,2	42,4	1,18	41,7	67	7,5	10	270	1530	60,3	750	29,6	1540	60,7	310	682
	ACS 11	2,11	74,5	1,87	66	1,65	58,3	67	11	15	270	1530	60,3	750	29,6	1540	60,7	330	726
	ACS 7 PLUS	1,39	49,1	1,2	42,4	1,18	41,7	67	7,5	10	270	1530	60,3	750	29,6	1540	60,7	335	737
	ACS 11 PLUS	2,11	74,5	1,87	66	1,65	58,3	67	11	15	270	1530	60,3	750	29,6	1540	60,7	355	781
1000	AC 15 (*)	3,01	106,3	2,65	93,6	2,4	84,7	69	15	20	-	1500	59,1	800	31,5	1200	47,3	460	1012
	AC 18 (*)	3,67	129,6	3,18	112,3	2,58	91,1	69	18,5	25	-	1500	59,1	800	31,5	1200	47,3	460	1012
	AC 22 (*)	3,95	139,5	3,6	127,1	3,1	109,5	69	22	30	-	1500	59,1	800	31,5	1200	47,3	465	1023
	AC 15 PLUS (*)	3,01	106,3	2,65	93,6	2,4	84,7	69	15	20	-	1500	59,1	800	31,5	1200	47,3	500	1100
	AC 18 PLUS (*)	3,67	129,6	3,18	112,3	2,58	91,1	69	18,5	25	-	1500	59,1	800	31,5	1200	47,3	500	1100
	AC 22 PLUS (*)	3,95	139,5	3,6	127,1	3,1	109,5	69	22	30	-	1500	59,1	800	31,5	1200	47,3	505	1111
2000	AC 30 (**)	6	211,9	5,7	201,3	4,9	173	68	30	40	-	1830	72,1	960	37,8	1670	65,8	800	1760
	AC 37 (**)	7,4	261,3	6,9	243,6	5,85	206,6	68	37	50	-	1830	72,1	960	37,8	1670	65,8	830	1826
	AC 45 (**)	9,9	349,6	8,7	307,2	7,2	254,2	68	45	60	-	1830	72,1	960	37,8	1670	65,8	940	2068
	AC 30 PLUS (**)	6	211,9	5,7	201,3	4,9	173	68	30	40	-	1830	72,1	960	37,8	1670	65,8	900	1980
	AC 37 PLUS (**)	7,4	261,3	6,9	243,6	5,85	206,6	68	37	50	-	1830	72,1	960	37,8	1670	65,8	930	2046
	AC 45 PLUS (**)	9,9	349,6	8,7	307,2	7,2	254,2	68	45	60	-	1830	72,1	960	37,8	1670	65,8	1040	2288

(\*) Version HH

(\*\*) Version H - HH

(\*) Available with energy recovery system (R).

(\*\*) Available with energy recovery system (R) or in water-cooled version (W).

F.A.D. in accordance with ISO 1217, annex "C"

Sound pressure level according to ISO 2151, tolerance  $\pm 3$ dB(A).

Working pressure: 7,5 bar for version 8 bar - 9,5 bar for version 10 bar - 12,5 bar for version 13 bar



**ITALY - ING. ENEA MATTEI SpA**

Strada Padana Superiore, 307  
20090 VIMODRONE (MI)  
Tel + 39 02253051 - Fax +39 0225305243  
E-mail: info@mattei.it

[www.matteigroup.com](http://www.matteigroup.com)

**UNI EN ISO 9001:2008**

**FRANCE**

MATTEI COMPRESSEURS  
Phone +33 535542205 - Fax +33 972316833  
E-MAIL: adv@mattei.fr - www.mattei.fr

**GERMANY**

MATTEI KOMPRESSOREN DEUTSCHLAND GmbH  
Phone +49 7151 5002560 - Fax +49 7151 5002565  
E-MAIL: info@mattei-kompressoren.de - www.mattei-kompressoren.de

**GREAT BRITAIN**

MATTEI COMPRESSORS Ltd  
Phone +44 (0)1789 450577 - Fax +44 (0)1789 450698  
E-MAIL: info@mattei.co.uk - www.mattei.co.uk

**U.S.A.**

MATTEI COMPRESSORS Inc  
Phone +1 410 5217020 - Fax +1 410 5217024  
E-MAIL: info@matteicomp.com - www.matteicomp.com

**RUSSIAN FEDERATION**

ING. ENEA MATTEI SpA  
Phone +7-495-739 41 90 - Fax +7-495-739 41 90  
E-MAIL: mattei@inbox.ru

**SPAIN**

ING. ENEA MATTEI SpA  
Phone +34 93 435 03 94 - Fax +34 93 455 26 76  
E-MAIL: info@mattei.it

**PEOPLE'S REPUBLIC OF CHINA**

Mattei (SuZhou) Air Compressors Manufacturing Co., Ltd  
WFOE by Ing. Enea Mattei SpA - Italy  
Tel: +86 512 66679986 Fax: +86 512 66679989  
E-MAIL: info@matteisuzhou.cn - www.matteisuzhou.com